

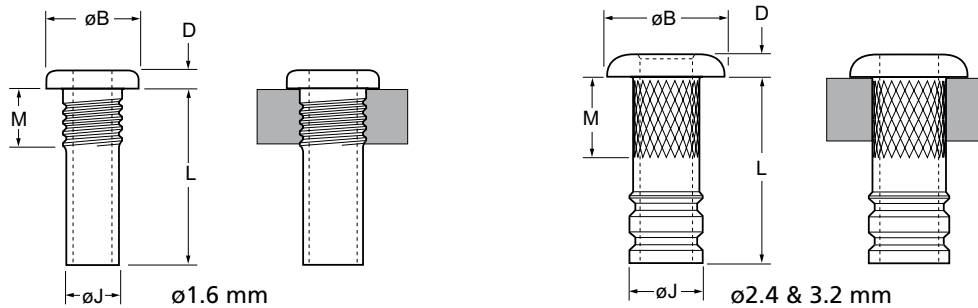

| English | Français | Deutsch | Italiano | Español |
|--------------|------------|------------------------|-------------|----------------|
| Dome head | Tête plate | Flachrundkopf | Testa tonda | Cabeza alomada |
| Brass* | Laiton* | Kupfer-Zink Legierung* | Ottone* | Latón* |
| Tin plated** | Étamé** | verzinkt** | Stagnato** | Estañado** |

*: BS EN 12166 CW 508L DIN 17660 CuZn37

** : We recommend tin plated parts 1107 Series are installed within 9 months from the date they were produced.
 Nous conseillons d'utiliser les pièces en laiton étamé du série 1107 sous un délai de 9 mois après la date de production.
 Wir empfehlen, verzinkte Nieten der Serie 1107 innerhalb 9 Monaten nach Produktionsdatum zu verarbeiten.
 Raccomandare di utilizzare i prodotti stagnati serie 1107 entro 9 mesi a decorrere dalla data di fabbricazione.
 Recomendamos utilizar sus piezas estañadas serie 1107 antes de 9 meses desde la fecha de su fabricación.

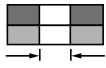

| Ø |  | | ØB | D | L | ØJ | M | No. of grooves cannelures Rillen rigature aros | Fasteners per pod Nombre de rivets par chargeur / Niete pro Magazin / Rivetti per caricatore / Uds./carga ± 1 | Part No/ref |
|----------------|---|------|------|------|------|------|------|--|---|-------------|
| | nom. | min. | | | | | | | | |
| 1.6 (1/16") | 1.80 | 1.93 | 2.80 | 0.61 | 4.11 | 1.79 | 2.04 | 4 | 62 | 01107-00205 |
| | | | | | 6.51 | | | | | |
| 2.4 (3/32") | 2.62 | 2.74 | 4.15 | 0.94 | 8.36 | 2.60 | 3.43 | 2 | 33 | 01107-00310 |
| | | | | | 9.96 | | | 3 | 28 | 01107-00312 |
| 3.2 (1/8") | 3.38 | 3.51 | 5.52 | 1.15 | 9.96 | 3.36 | 3.43 | 3 | 26 | 01107-00412 |

all dimensions in mm / en millimètres / alle Maße in mm / in millimetri / en milímetros